

**JOINT UNIVERSITIES PRELIMINARY EXAMINATIONS BOARD**

**2015 EXAMINATIONS**

**PHYSICS: SCI-J155**

**MULTIPLE CHOICE QUESTIONS**

1. A particle with rest mass  $m$  moves with speed  $0.6c$ . Its kinetic energy is .....

  - A.  $0.18mc^2$
  - B.  $0.22mc^2$
  - C.  $0.25mc^2$
  - D.  $mc^2$

2. Which of the following particles is stable?
  - A. Neutron
  - B. Proton
  - C. Pion
  - D. Muon
3. To travel at a constant speed, a car engine provides 24 KW of useful power. The driving force on the car is 600 N. At what speed does it travel?
  - A.  $2.5 \text{ m s}^{-1}$
  - B.  $4.0 \text{ m s}^{-1}$
  - C.  $25 \text{ m s}^{-1}$
  - D.  $40 \text{ m s}^{-1}$

4. A pure semiconductor at room temperature has:
- A. more electrons/m<sup>2</sup> in its conduction band than holes/m<sup>2</sup> in its valence band
  - B. more electrons/m<sup>2</sup> in its conduction band than a typical metal
  - C. more electrons/m<sup>2</sup> in its valence band than at T=0K
  - D. more electrons/m<sup>2</sup> in its conduction band than at T = 0K.
5. The proper time between two events is measured by clocks at rest in a reference frame in which the two events
- A. occur at the same time
  - B. occur at the same coordinates
  - C. occur at separate coordinates
  - D. occur at separate times and separate coordinates
6. A handbag weighing 162 N is carried by two students each holding the handle of the bag next to him. If each handle is inclined at 60° to the vertical, find the force on each student's arm
- A. 324 N
  - B. 162 N
  - C. 121 N
  - D. 81 N
7. A rope is being used to pull a mass of 10 kg vertically upward. Determine the tension on the rope, if starting from rest, the mass acquires a velocity of 4 ms<sup>-1</sup> in 8s [g= 10ms<sup>-2</sup>].
- A. 105 N
  - B. 95 N
  - C. 50 N
  - D. 55 N

8. A boy observes a piece of stone at the bottom of a river 6.0 m deep. If he looks vertically from the surface of the river, how far does the stone appear to be from him?

$$\left[ \text{Refractive index of water} = \frac{4}{3} \right]$$

- A. 8.0 m
  - B. 4.5 m
  - C. 6.0 m
  - D. 5.5 m
9. A cell has an internal resistance of  $0.01 \Omega$ . An instrument that can measure the resistance accurately is .....
- A. Ohm- meter
  - B. Potentiometer
  - C. Electroscope
  - D. oscilloscope
10. A conductor of length 2m carries a current of 0.8A while kept in a magnetic field of magnetic flux density 0.5 T. The maximum force acting on it is
- A. 16.2N
  - B. 8.0N
  - C. 3.2N
  - D. 0.8N
11. The bond that forms a semiconductor is
- A. Covalent
  - B. Electrovalent
  - C. Metallic
  - D. Electrostatic

12. The particle nature of light is demonstrated by
- A. Photoelectric effect
  - B. Speed of light
  - C. Colours of light
  - D. Diffraction of light
13. ----- law states that at constant pressure, the volume of a given mass of gas is directly proportional to the absolute temperature.
- A. Charle's
  - B. Gay Lussac's
  - C. Boyle's
  - D. Pascal's
14. Use dimensional analysis to determine which of the following equations is certainl  
wrong:
- I.  $\lambda=vt$
  - II.  $F=m/a$
  - III.  $F=mv/t$
  - IV.  $h=v^2/2g$
  - V.  $v=(2gh)^{1/2}$
- A. I only
  - B. I and II
  - C. II and III
  - D. II only
15. A ----- can hear sound as high as 100,000Hz
- A. cat
  - B. bat
  - C. goat
  - D. dog

16. For an electron to be ejected from the surface of a metal, the radiation energy must be

-----

- A. greater than the work function of the metal<sup>3</sup>
- B. less than the work function of the metal
- C. equal to the work function of the metal
- D. greater than the rest mass energy of the electron

17. ----- is the only natural satellite of the earth

- A. stars
- B. mercury
- C. sun
- D. moon

18. A 2-kilogram block rests at the edge of a platform that is 10 meters above level ground.

The block is launched horizontally from the edge of the platform with an initial speed of 3 meters per second. Air resistance is negligible. The time it will take for the block to reach the ground is approximately ..... [Take  $g = 10 \text{ m/s}^2$ ].

- A. 0.3 s
- B. 1.0 s
- C. 1.4 s
- D. 2.0 s

19. A diver initially moving horizontally with speed  $v$  dives off the edge of a vertical cliff and lands in the water a distance  $d$  from the base of the cliff. How far from the base of the cliff would the diver have landed if the diver initially had been moving horizontally with speed  $2v$ ?

- A.  $d$
- B.  $3d$
- C.  $2d$
- D.  $4d$

20. A truck traveled 400 meters north in 80 seconds, and then it traveled 300 meters east in 70 seconds. The magnitude of the average velocity of the truck was most nearly
- 1.2 m/s
  - 3.3 m/s
  - 4.6 m/s
  - 6.6 m/s
21. The field intensity at a point close to a charged plane conductor situated in air is  $3.5 \times 10^6 \text{ Vm}^{-1}$ . The surface density of charge is:  
[Take the permittivity of free space as  $8.85 \times 10^{-12} \text{ F/m}$ ]
- $2.53 \mu\text{Cm}^{-2}$
  - $26.55 \times 10^{-12} \text{ Cm}^{-2}$
  - $31.0 \times 10^{-12} \mu\text{Cm}^{-2}$
  - $31.0 \mu\text{Cm}^{-2}$
22. Two parallel horizontal metal plates are 25 mm apart and a potential difference of 1000 V is applied across the plates. The field intensity between the plates is:
- $40 \text{ Vm}^{-1}$
  - $25000 \text{ Vm}^{-1}$
  - $40 \text{ kV m}^{-1}$
  - $2.5 \text{ kVm}^{-1}$ .
23. Which of the following defines the Heisenberg uncertainty principle for position and momentum?
- $\Delta x \Delta p \leq \hbar/2$
  - $\Delta x \Delta p = \hbar/2$
  - $\Delta x \Delta p \geq \hbar/2$
  - $\Delta x \Delta p \geq 2\hbar$
24. The ejection of an alpha particle from a nucleus results in
- an increase in the atomic number by one
  - an increase in the atomic mass by four
  - a decrease in the atomic number by two
  - none of the above

25. Hydrogen-3 is a radioactive isotope of hydrogen. Which type of radiation would you expect an atom of this isotope to emit?

- (i) beta particle
- (ii) an alpha particle
- (iii) a gamma ray

- A. (i) only
- B. (ii) only
- C. (i) and (iii)
- D. (i), (ii) and (iii)

26. Which of the following are derived units?

- (i) metres
- (ii) Coulomb
- (iii) Kilogram
- (iv) Ampere
- (v) Joule

- A. I and III only
- B. II and V only
- C. II, IV and V only.
- D. I, II, III and IV

27. The dimension of power is

- A.  $ML^2T^{-3}$
- B.  $MLT^{-2}$
- C.  $ML^2T^{-2}$
- D.  $ML^{-2}T^3$

28. Which of the following quantities has the same unit as kilowatt – hour?
- A. Force x acceleration
  - B. Force x Velocity
  - C. Force x distance
  - D. Force x time
29. An elastic string of length 20cm extends to 24cm when it supports a weight of 50N. The energy stored in the string is?
- A. 1J
  - B. 2J
  - C. 5J
  - D. 10J
30. Which of the following radiations will pass through a sheet of paper?
- (I) Alpha rays
  - (II) Beta rays
  - (III) Gamma rays
- A. I only
  - B. I and III only
  - C. I, II and III only
  - D. II and III only
31. A metal having a work function of 5.76eV is illuminated with a radiation of 7.88eV. The kinetic energy of the electrons emitted from the metal surface is
- A. 2.12eV
  - B 1.37eV
  - C. 45.39eV
  - D. 13.64eV



32. What is the energy associated with an X-ray of wavelength  $9 \times 10^{-10} \text{m}$   
(Planck's constant =  $6.6 \times 10^{-34} \text{Js}$  and velocity of light  $3 \times 10^8 \text{m/s}$ ).
- A.  $7.5 \times 10^{14} \text{J}$   
B.  $2.20 \times 10^{-16} \text{J}$   
C.  $7.5 \times 10^5 \text{J}$   
D.  $1.3 \times 10^{-15} \text{J}$
33. Two football players with masses 75 kg and 100 kg run directly toward each other with speeds of 6 m/s and 8 m/s respectively. If they grab each other as they collide, the combined speed of the two players just after the collision would be:
- A. 2 m/s  
B. 3.4 m/s  
C. 4.6 m/s  
D. 7.1 m/s
34. The velocity of sound in a gas is given by  $v_s = \sqrt{\frac{\gamma P}{\rho}}$  where the symbols have their usual meanings. For a particular gas under certain conditions,  $v_s$  is found to be  $400 \text{ms}^{-1}$ . What is the new value of  $v_s$  if the pressure were reduced by 5%?
- A.  $89.4 \text{ms}^{-1}$   
B.  $20 \text{ms}^{-1}$   
C.  $100 \text{ms}^{-1}$   
D.  $390 \text{ms}^{-1}$
35. Which of the following statement is/are true of interference of waves?
- (I) It is a result of superposition of two or more waves.  
(II) It can be explained using corpuscular nature of light.  
(III) It can be explained using wave nature of light waves  
(IV) Only the wave-particle duality of light can be used to explain interferences.  
(V) It produces bright and dark fringes.
- A. I and III only  
B. I and IV only  
C. I, II and V only  
D. I, III and V only

36. Resistance of a material depends on the following except
- A. temperature
  - B. length and cross-section area of the material
  - C. nature of the material
  - D. shape of the material
37. An X-ray tube takes a current of 7.0 mA and operates at a potential difference of 80 kV. What power is dissipated?
- A. 460 W
  - B. 560 W
  - C. 660 W
  - D. 760 W
38. Which of the following describes what occurs in the fission process?
- A. A heavy nucleus is fragmented into lighter ones.
  - B. A neutron is split into a neutron and proton.
  - C. Two light nuclei are combined into a heavier one.
  - D. A proton is split into three quarks.
39. The coordinate of a particle in meters is given by  $x(t) = 16t - 3.0t^3$ , where the time  $t$  is in seconds. The particle is momentarily at rest at  $t =$
- A. 0.75 s
  - B. 1.3s
  - C. 5.3s
  - D. 7.3s
40. The maximum efficiency of a heat engine which operates between the measured temperatures of 227 °C and 727 °C is
- A. 50 %
  - B. 20 %
  - C. 30 %
  - D. 40 %

41. The stopping potential for electrons ejected by  $6.8 \times 10^{14}$  Hz electromagnetic radiation incident on a certain sample is 1.8V. The kinetic energy of the most energetic electrons ejected and the work function of the sample, respectively, are
- A. 1.8eV, 2.8eV
  - B. 1.8eV, 1.0eV
  - C. 1.8eV, 4.6eV
  - D. 2.8eV, 1.0eV.
42. When a kaon decays via the strong interaction the products must include a:
- A. baryon
  - B. lepton
  - C. strange particle
  - D. electron
43. A particle with spin angular momentum is called a:
- A. lepton
  - B. hadron
  - C. fermion
  - D. boson.
44. Which of the following consists entirely of vector quantities?
- A. velocity, magnetic flux and reaction
  - B. tension, magnetic flux and mass
  - C. displacement, impulse and power
  - D. work, pressure and moment

45. Two forces each of 10N act on a body, one towards the north and the other towards the east. The magnitude and the direction of the resultant force are
- A. 10N, 45°W
  - B. 20N, 45°E
  - C.  $10\sqrt{2}$  N, 45°W
  - D.  $10\sqrt{2}$  N, 45°E
46. The main reason for making the cover of a vacuum flask air tight is to prevent heat loss by
- A. conduction
  - B. evaporation
  - C. radiation
  - D. convection
47. A cell can supply currents of 0.4A and 0.2A through a 4.0Ω and 10.0Ω resistors respectively. The internal resistance to the cell is
- A. 0.5Ω
  - B. 1.0Ω
  - C. 1.5Ω
  - D. 2.0Ω
48. A working electric motor takes a current of 1.5A when the p.d. across it is 250V. if its efficiency is 80%, the power output is
- A. 562.0W
  - B. 469.0W
  - C. 300.0W
  - D. 133.0W

49. At what frequency would a capacitor of  $2.5\mu\text{F}$  used in radio circuit have a reactance of  $250\Omega$ ?

A.  $200\pi$  Hz

B.  $\frac{\pi}{800}$  Hz

C.  $\frac{800}{\pi}$  Hz

D.  $8000\pi$  Hz

50. A certain radioactive source emits radiations that were found to be deflected by both magnetic and electric fields. The radiations are

A. ultra-violet rays

B. gamma rays

C. alpha rays

D. beta rays

## PHYSICS ESSAY QUESTIONS

### Instruction:

**PHS 001: Questions 1 and 5**

**PHS 002: Questions 2 and 6**

**PHS 003: Questions 3 and 7**

**PHS 004: Questions 4 and 8**

- 1 (a) From a consideration of the flow of a liquid through a narrow tube, define viscosity. Express the coefficient of viscosity  $\eta$  in terms of the internal frictional force  $F$ , surface area  $A$  of the liquid and velocity gradient  $\frac{dv}{dx}$  and derive its units using dimensional analysis. **[2 Marks]**
- (b) i. Discuss qualitatively the motion of a small metal ball allowed to drop downwards in a long vertical tube of viscous liquid so that it moves along the axis of the tube. Sketch the variation of velocity  $v$  with time  $t$ . **[3 Marks]**
- ii. Write down the equation relating the velocity  $v$  of a ball bearing of radius  $r$  and mass  $m$  falling vertically, from rest, in a viscous liquid after an elapsed time  $t$ . The effect of the buoyancy of the liquid should be neglected. Obtain an expression for the terminal velocity  $v_0$ . **[2 Marks]**
- (c) An object is thrown forward horizontally from the top of a cliff 20 m high with a horizontal velocity of 15 m/s. Calculate:
- i. The time to return to the ground
- ii. The horizontal distance from the foot of the cliff at which the object strikes the ground. [Take  $g = 10 \text{ m/s}^2$ ]. **[3 Marks]**
2. (a) A narrow beam of light traveling in air is incident on a slab of transparent material. The incident beam makes an angle of  $40.0^\circ$  with the normal, and the refracted beam makes an angle of  $26.0^\circ$  with the normal. (Refractive index = 1.00 for air). Use Snell's law of refraction to:
- i. find the index of refraction of the slab material. **[2 Marks]**

ii. A ray of light, travelling in crown glass of refractive index 1.52, is incident on glass-air interface. Calculate the incident angle at which the total internal reflection begins to occur. **[2 Marks]**

iii. Draw a diagram to support your answer in (ii) above. **[1 Marks]**

iv. Explain the concept of total internal reflection. **[2 Marks]**

(b) Complete the table of the image properties for converging and diverging lenses below: **[3 Marks]**

Cases	Lens type	Object	Image			
		Position	Position	Orientation	Size	Type
1	Converging	$>2f$	$<2f$	Inverted	Smaller	Real
2	Converging	$2f$	(i)	Inverted	Same Size	Real
3	Converging	$>f$ but $<2f$	$>2f$	(ii)	Larger	Real
4	Converging	(iii)	No image is formed			
5	Converging	$<f$	$>f$	upright	Larger	(iv)
6	Diverging	Any position	$<f$	upright	(v)	Virtual

3 (a) State Ohm's law. **[1 Mark]**

(b) A battery of emf 24 V and internal resistance  $r$  is connected to a circuit having two parallel resistors of  $3\Omega$  and  $6\Omega$  in series with an  $8\Omega$  resistor.

The current flowing in the  $3\Omega$  resistor is 0.8A. Calculate **[6 Marks]**

- i. The current in the  $6\Omega$  resistor.
- ii. The internal resistance  $r$  of the battery.
- iii. The terminal potential difference of the battery.

(c) i. Define the capacitance of a capacitor. **[1 Mark]**

ii. A capacitor carrying  $10\mu C$  charge has a voltage of 50 V across its plates.

- Calculate its capacitance and the energy stored in it. **[2 Marks]**
- 4 (a) Define radioactivity. **[1 Mark]**
- (b) Calculate the total binding energy of an alpha particle. The masses of the neutron, proton and alpha particles are respectively 1.008665 u, 1.007825 u and 4.002603 u. ( $1\text{u} = 931.5 \text{ MeV}/c^2$ ). **[3 Marks]**
- (c) i. Define half – life of a radioactive substance. **[1 Mark]**
- ii. Show that half-life  $T_{\frac{1}{2}} = \frac{\ln 2}{\lambda}$  **[2 Marks]**  
 is the decay constant.
- iii. A radioactive material has as initial activity of 7000 counts per second and an activity of 875 counts per second after 6 hrs. What is the half – life of the material? **[3 Marks]**
- 5 (a) Differentiate between scalar and vector quantities and give two examples in each case **[3 Marks]**
- (b) i. At a stage in the launch of a satellite the force due to thrust is equal to the gravitational force. Determine the rate of change of the satellite's momentum at that instant. **[2 Marks]**
- ii. A truck accelerates uniformly from rest at  $2 \text{ ms}^{-2}$  for 10 s, maintains a steady velocity for 30 s, and is then brought to rest in 5 s under uniform retardation. Calculate the total distance travelled by the truck. **[2 Marks]**
- (c) A projectile is launched with an initial velocity of 35 m/s at an angle of  $40^\circ$  to the horizontal. Find
- i. The maximum height attained,  
 ii. Total time of flight,  
 iii. Range  
 (Take  $g = 9.8\text{m/s}^2$ ). **[3 Marks]**
6. (a) State how three features of a thermo flask is used to heat loss. **[3Marks]**
- (b) i. State Zeroth law of thermodynamics. **[1 Mark]**  
 ii. Give an implication of this law. **[1Mark]**
- (c) i. A steel rod has a length of 30m at  $0^\circ\text{C}$ . Calculate the length of the rod



after it has been heated to  $40^{\circ}\text{C}$ , given that the linear expansion coefficient is  $11 \times 10^{-6}/^{\circ}\text{C}$ .

[2 Marks]

- ii. A  $0.050 \text{ kg}$  steel mass, heated to  $200.0^{\circ}\text{C}$  is dropped into a beaker containing  $0.400 \text{ kg}$  of water. The initial temperature of the water is  $20.0^{\circ}\text{C}$  and the final temperature with the steel is  $22.4^{\circ}\text{C}$ . Calculate the specific heat of the steel mass. Assume the beaker has negligible heat capacity. Specific heat capacity of water =  $4186 \text{ J/kg}^{\circ}\text{C}$ .

[3 Marks]

7. (a) Explain what is meant by a *field of force*.

[1 Mark]

(b) State Coulomb's Law.

[1 Mark]

(c) A negative charge of  $6.0 \times 10^{-6} \text{ C}$  exerts an attractive force of  $65 \text{ N}$  on a second charge that is  $0.050 \text{ m}$  away. What is the magnitude of the second charge?

[3 Marks]

( $\epsilon_0 = 8.85 \times 10^{-12} \text{ F/m}$ )

(d) Find the currents  $I_1, I_2,$  and  $I_3$  in the circuit below.

[5 Marks]

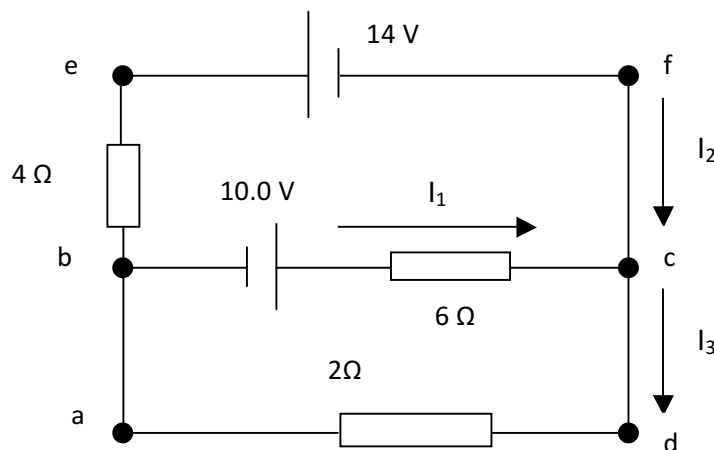

8. (a) Explain the term wave-particle duality.

[1 Mark]

(b) i. Write down, without proof, de Broglie's relation.

[1 Mark]

ii. A bullet of mass  $20 \text{ g}$  is moving with a speed of  $300 \text{ ms}^{-1}$ . Calculate the de Broglie wavelength of the bullet.

[3 Marks]

(c) Define the following: Photoelectric effect and work function.

[2 Marks]

(d) The threshold frequency for a metal surface is  $3 \times 10^{14} \text{ Hz}$ , if the metal is illuminated with a radiation of  $7.88 \text{ eV}$ . What is the kinetic energy of the electrons emitted from the metal surface?

[ Planck constant,  $h = 6.6 \times 10^{-34} \text{ J.s}$ ,  $1 \text{ eV} = 1.602 \times 10^{-19} \text{ J}$ ].

[3 Marks]

